



G.M.s.r.l.
Ghirri Motoriduttori

Serie MV/V - MRV/RV



**Installation use and
Maintenance Manual**

GHIRRI MOTORIDUTTORI



INSTALLATION USE AND MAINTENANCE MANUAL Serie MV/V – MRV/RV

INDEX

| | | |
|------------|--|--------|
| 1.0 | GENERAL INFORMATION | Pag.3 |
| | 1.1.1 EQUIPMENT IDENTIFICATION | |
| | 1.1.2 MANUFACTURER'S LIABILITY | |
| | 1.1.3 OPERATING LIMITS AND CONDITIONS | |
| 2.0 | GEARBOXES'ATEX INFORMATION | Pag.5 |
| | 2.1 EQUIPMENT IDENTIFICATION | |
| | 2.2 CONFORMITY TO ATEX STANDARDS | |
| | 2.3 BUILDING CHARACTERISTIC ATEX GEARBOXES | |
| | 2.4 ATEX CERTIFICATE | |
| 3.0 | STORAGE AND INSTALLATION | Pag.8 |
| | 3.1 STORAGE AND WAREHOUSE | |
| | 3.2 INSTALLATION | |
| | 3.3 STARTING | |
| 4.0 | MAINTENANCE | Pag.11 |
| | 4.1.1 ROUTINE MAINTENANCE | |
| | 4.1.2 LUBRICANTS | |
| | 4.1.3 CHECKING EFFICIENCY | |
| 5.0 | PROBLEM DURING OPERATION | Pag.14 |
| | 5.1 CAUSE AND REMEDY | |
| 6.0 | MOUNTING POSITION | Pag.15 |
| 7.0 | SPARES TABLES | Pag.25 |
| 8.0 | SPARES TABLES | Pag.25 |
| 9.0 | SPARES TABLES | Pag.25 |

1.0 GENERAL INFORMATION

1.1 EQUIPMENT IDENTIFICATION

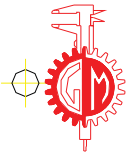
| | | | |
|---|------|---|---|
|  <p>GHIRRI MOTORIDUTTORI</p> <p>FORMIGINE (MO) ITALY TEL. 059 558210</p> | A | | |
| | RAP. | B | |
| | C | | |
| | D | | |
| | DATA | E | F |
| | | | |

- a) Gearbox's description
- b) Ratio
- c) Product identification
- d) Gearbox code
- d) Date
- e) Operator code

1.2 NOTE AND MANUFACTURER'S LIABILITY

The manufacturer declines all liability for cases of:

- use of the gearbox in violation of local laws on safety and accident prevention at work
- use as overgear
- modifications and/or tampering
- incorrect installations
- non-observance of instruction given in this manual
- incorrect power supply
- work done by unqualified or unsuitable person
- immersion in water or other liquids
- use in environment with different pressure than the atmospheric one
- use in aggressive or brackish environment

The safety also depends on the following elements:

- use of gearbox within its operative limits
- diligently observance of the routine maintenance schedule
- exclusive use of original spare parts.



N.B. :The instructions given in this manual do not substitute, but summarise the provisions of applicable safety legislation.

1.3 OPERATING LIMITS AND CONDITIONS

- the gearbox must be installed as specified in the order and as given on the serial plate
- the permissible ambient temperature is: $-20^{\circ} < t_a < +40^{\circ} \text{ C}$
- the instructions given in the Use and Maintenance Manual, must be followed
- the use in a poorly lit area must provide for the use of additional lamps with applicable safety legislation
- the catalogue data refers to standard installation conditions: smaller spaces could cause an increase of temperature; in this case ask the manufacturer

For gearboxes ATEX it is also valid:

- The input speed must not exceed 1500 rpm
- Do not use the gearbox, if not authorized ATEX, in a potentially explosive atmosphere



Failure to obtain said conditions voids the warranty of the manufacturer and in case of ATEX gearboxes, the certification too.

2.0 GEARBOXES' ATEX INFORMATIONS

2.1 EQUIPMENT IDENTIFICATION

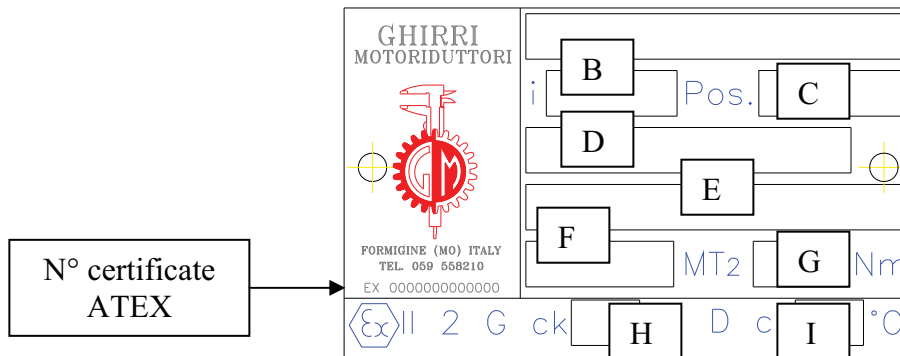

- Gearbox's description
- Gear ratio
- Mounting position
- Gearbox code
- Product identification
- Date of manufacture
- Maximum transmissible torque
- Temperature class, or maximum surface temperature
- Maximum surface temperature

2.2 CONFORMITY TO ATEX STANDARDS

The conformity declaration here reported, certify the Conformity to the ATEX directive 94/9/CE; the validity of the declaration depends to the respect of the instruction specified in the Installation use and maintenance manual.

Equipment group : **II**

Calass : Gas **2G** –Dust **2D**

Zone : Gas **1** – Dust **21**

Temperature under the following classification :

D-160 : the reduction unit may be installed in zones 21 and 22 (categories 2D and 3D), the surface temperature is guaranteed at less than 160° C.

D-130 : the reduction unit may be installed in zones 21 and 22 (categories 2D and 3D), the surface temperature is guaranteed at less than 130° C.

G-T3 : the reduction unit may be installed in zones 1 and 2 (categories 2G and 3G), the surface temperature is guaranteed at less than 200° C (class T3)

G-T4 : the reduction unit may be installed in zones 1 and 2 (categories 2G and 3G), the surface temperature is guaranteed at less than 135° C (class T4)



The applicability of these options is subject to the type of reduction unit in question and is given in the selection table.

2.3 BUILDING CHARACTERISTIC ATEX GEARBOXES

- Viton seal rings
- Twin-lip seals on slow shaft
- No plastic components
- Marking on rating plate stating protection category and type
- Presence of irreversible temperature-indicators at strategic points
- Thread locker on all external bolts
- Vent caps with anti-intrusion valve
- Only uses synthetic lubricants (Polyglycol or Polyalkalene Glicol family)
- Seal in zones with moving couplings and external threaded seats
- Products and components suitable for use at temperatures above envisaged operating temperatures
- No sliding metal components outside the reduction unit

2.4 ATEX CERTIFICATE

ZERTIFIKAT • CERTIFICATE • CERTIFICADO • CERTIFICAT
記証証書 • СЕРТИФИКАТ • CERTIFICATE • CERTIFICADO • CERTIFICAT



EC-Certificate
No. EX9 04 07 53496 001

Holder of Certificate: G.M. S.r.l.
Ghirri Motoriduttori
Via Prampolini, 6
41043 Formigine (MO),
Italy

Name of Object: Non-electric devices and components group II
Worm Gearboxes

Model(s):  Worm Gearboxes
Type: MRV

Description of Object: One set of technical documentation.

This EC-Certificate is issued according to Article 8(1) b) ii) of Council Directive 94/9/EC for equipment and protective systems intended for use in potentially explosive atmospheres (ATEX). It confirms the receipt and storage of the file for the listed product by TÜV PRODUCT SERVICE GMBH. It was not verified whether the documentation is correct and complete. See also notes overleaf.

Test report no.: 70076361

Date: 2004-07-13





TÜV PRODUCT SERVICE GMBH is Notified Body according to Council Directive 94/9/EC for equipment and protective systems intended for use in potentially explosive atmospheres, notified by publication in the Official Journal of the EC with identification No. 0123.

Page 1 of 1

**TÜV PRODUCT SERVICE GMBH • Zertifizierstelle • Ridlerstrasse 65 • D-80339 München
Gruppe TÜV Süddeutschland**

3.0 STORAGE AND INSTALLATION

3.1 STORAGE AND WAREHOUSE

The reducers can be stored in an inoperative condition (normal industrial environment) without having to take any special precautions for a period of about 6 months; if they remain inoperative for a longer period, the surface protective devices on the rotating parts should be reset and the lubricant topped up completely.

At the end of the storage, before the reducer is put back into operation do the following:

- The output shafts and external surfaces must be thoroughly cleaned of all rustproofing product or other impurities



- **(n.b. : in case of ATEX gearbox, the previous disposition has to be done outside the explosion hazard area)**
- the solvent must not touch the seal rings as this can damage them and render them ineffective.
- if the oil or protective material used during storage is not compatible with the oil used during the machine's operation, the interior of the unit must be thoroughly cleaned before filling with the operating oil.

3.2 INSTALLATION

It's very important that the following standards be met when installing the gear reducer and/or gearmotor:

- Make sure that the gear reducer is aligned with the motor and with the operating machine.
- Ensure that the reducer is secured firmly to avoid any vibration.
- The elements (cable or solid) must be mounted on the shafts in a workmanlike manner, without forcing, to ensure that the couplings are sound and thereby avoiding any damage to the bearings or other parts of the reducer. The elements in question must be machined to ISO H7 tolerance levels.
- If the reducer is painted, the rotating parts, control devices (oil indicator lamps) and particularly the oil seals, should be protected to ensure that they are kept in good working order.

- Before putting the machine into operation, check that the position of the oil level indicator and the drain plug are appropriate in relation to the position in which the reducer has been mounted and that there is adequate oil to lubricate the internal working parts.
- If the machine is installed in the open air or in environments subjected to particularly harsh conditions, a rust-proofing paint should be used and water-repellent grease should be applied to the rotating parts.
- When the reducer is supplied without motor, check that the shaft and motor flange tolerances satisfy IEC Standards. Clean off any traces of dirt or paint from the shaft, centring pin and flange plate. Couple the elements without forcing them in any way.



In case of ATEX gearbox, must be add the following disposition:

Category 2D gear units must be installed in compliance with the provisions of standards EN 1127-1 EN 50281-2.

All maintenance, assembly and disassembly work must be done outside the explosion hazard area by trained personnel.

Install guards to prevent the hazardous accumulation of dust and liquids on the seals.

Only install the gear unit in the motor execution and mounting position specified on the order.

Do not connect any object with electrical resistance greater than 10^9 ohm to the gear unit.

Check that all accessory components (cables, cable glands, etc.) comply with ATEX directive.

3.3 STARTING

The gearbox has been tested by the manufacturer.

Any way during the starting operation it is necessary to respect following instructions:

- The machine incorporating the gear unit must be comply with the provisions of the Machinery Directive 98/37/CE and any other applicable safety legislation.
- The gear unit's mounting position in the installation must correspond to that prescribed and indicated on the nameplate.

- The motor power supply must correspond to that indicated on the motor within the tolerances indicated in the regulations in force
- The oil level must be as indicated in the catalogue and oil leaks should not be present
- The starting must be in a gradual way avoiding to put the nominal torque immediately on the gear unit
- The unit musn't run noisily or with excessive vibration
- The environment temperature must be within the allowed range



In case of ATEX gearboxes it must be add following disposition:

- The machine incorporating the gearbox must comply with the provisions of the Directive 94/9/CE.
- Check that assembly is not carried out in a potentially explosive atmosphere.
- Check that there is no dust deposits thicker than 5 mm on the gearbox. Anyway the gearbox must be clean before starting.
- Check that during operation, the gearbox is sufficiently ventilated and that it is not subject to radiation from external heat sources.
- Check that the maximum operating temperature after 3 hours of starting at full load is not higher than the standard temperature class of the gearbox. **In case stop the gearbox at once and contact the G.M. technical service.**

4.0 MAINTENANCE

4.1 ROUTINE MAINTENANCE

Generally the following rules should be followed: periodically check that the exterior of the assembly is clean, periodically check of eventual lubricant's leaks, periodic replacement of lubricant if gearbox is not lubricated for life.

Periodic check provides too:

- check the breather hole in the plug is clean(when present)
- check through the level plugs the correct quantity of lubricant, if it is necessary, procede with refilling of lubricant of the same brand or anyway compatible with that of the gearbox.



In case of ATEX gearbox is indicated the following frequency :

| Frequency | Component | Type of work | Operation |
|--|---------------------------|--|---|
| 5000 hours | Seals and gaskets gearbox | Check wear or ageing | If it is necessary replacing of the oil seals ring |
| 1000 hours | Lubricant | Check oil level and check for leaks | Maintenance or refilling |
| 1000 hours | Hole plug | Check hole's cleaning | Maintenance |
| 1000 hours of operation or every 3months | Surface | Check that there is no dust deposits thicker than 5 mm | Periodic cleaning |
| 1000 hours of operation or every 3months | Surface | Check the surface temperature | Check of the temperature indicator |
| Every 5000 hours of operation | Gearbox | General repair of the gearbox (if it is not necessary in advance because of anomalies) | Replacing of bearings and mechanical components which are wearred |

4.2 LUBRICANT

| | Synthetic Oli | Mineral Oil |
|--------|-------------------------------|----------------|
| AGIP | TELIUM OIL VSF 320 (*) | BLASIA 220 |
| SHELL | Tivela OIL SC 320 | OMALA 220 |
| KLUBER | Syntheso D 220 EP | Lamora 220 |
| FINA | Giran S 320 | Giran 220 |
| ESSO | Glycolube Range 220 | Spartan EP 220 |



In case of ATEX gearbox, greases and oils compatibles are:

Greases

For greased gear trains

Shell TVX Compound B

Shell Tivela GL 00

To facilitate coupling of cylindrical parts

Kluberpaste 46 MR 401

For greasing contact seals

ITP Fluorocarbon gel 880

Oils(as alternatives to ENI Telium oil VSF 320)

- Shell : Tivela Oil SC320
- Aral : Degol GS 320
- Kluber : Klubersynth GH 6 320
- Total : Carter SY 320
- Mobil : Glygoyle HE 320

4.2 4.3 CHECKING EFFICIENCY

Remove dust deposits from the gear unit.

Check the noise and the presence of eventual vibration.

Check the power absorption of voltage is within limit indicated in the name plate.

Check for lubricant leaks.



In case of ATEX gearboxes :

The following activities should be integrated in the internal procedure.

5.0 PROBLEM DURING OPERATION

The following table shows a series of problems with a description of possible remedies.

However the information given is for reference only, as all the drives manufacturer by G.M. are thoroughly tested and checked before shipment.



Tampering with the assembly without prior authorization from G.M. immediately invalidates the warranty and makes it impossible to ascertain the causes of a defect or malfunction.

| problem | cause | action |
|--|--|--|
| The motor does not start. | Problems with power supply. Defective motor.Wrong size of motor. | Replace electric motor and/or check power supply. |
| Current absorbed by the motor is greater than shown on the data plate. | Wrong size of motor. | Check the application. |
| Temperature of the motor housing is very high. | Wrong size of motor /defective motor. | Check the application. |
| Temperature of the motor housing is very high. | Wrong size of reduction unit. Mounting position does not comply with the order. | Check the application and/or mounting position complies with the order. |
| Oil leak from oil seal. | Defective oil seal.Oil seal damaged during shipment. Defective motor shaft. | Replace the oil seal, return the assembly to G.M. if motor shaft is damaged. |
| Oil leak from joint. | Flat gasket or O-ring damaged. | Return the assembly to G.M. |
| Intermittent noise from the gears. | Dents in the gear wheels. | Return the assembly to G.M.(if the noise has effect on the application). |
| Noise(whine)from the drive assembly. | Bearings incorrectly adjusted. Gears with mesh errors. Insufficient lubricant. | Check of lubricant and/or return the assembly to G.M. |
| Electric motor vibrates. | Measurement of the assembly coupling. | Replace electric motor and/or check geometric tolerance of flange on electric motor. |
| The main shaft rotates the wrong way. | Incorrect connection of the electric motor. | Swap phases. |

6.0 SPARES TABLE

GEARED MOTOR REDUCERS MRV/RV

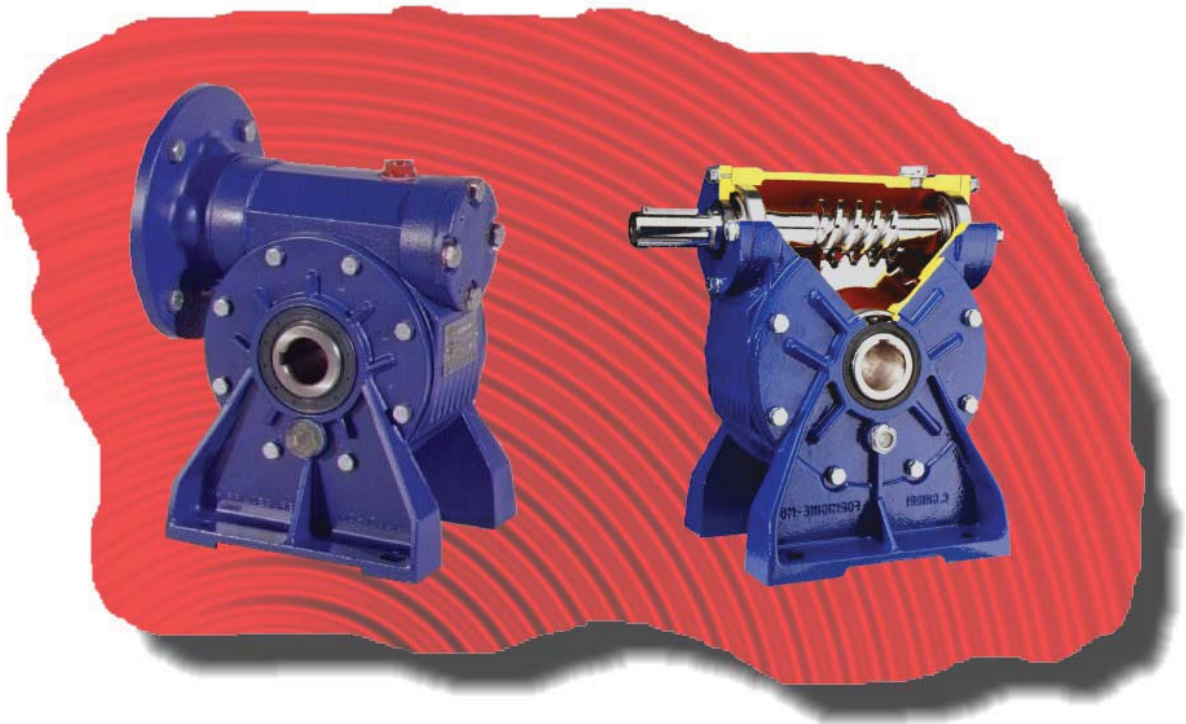

MRV PAM
n° compl. 01001.1
13/03/05

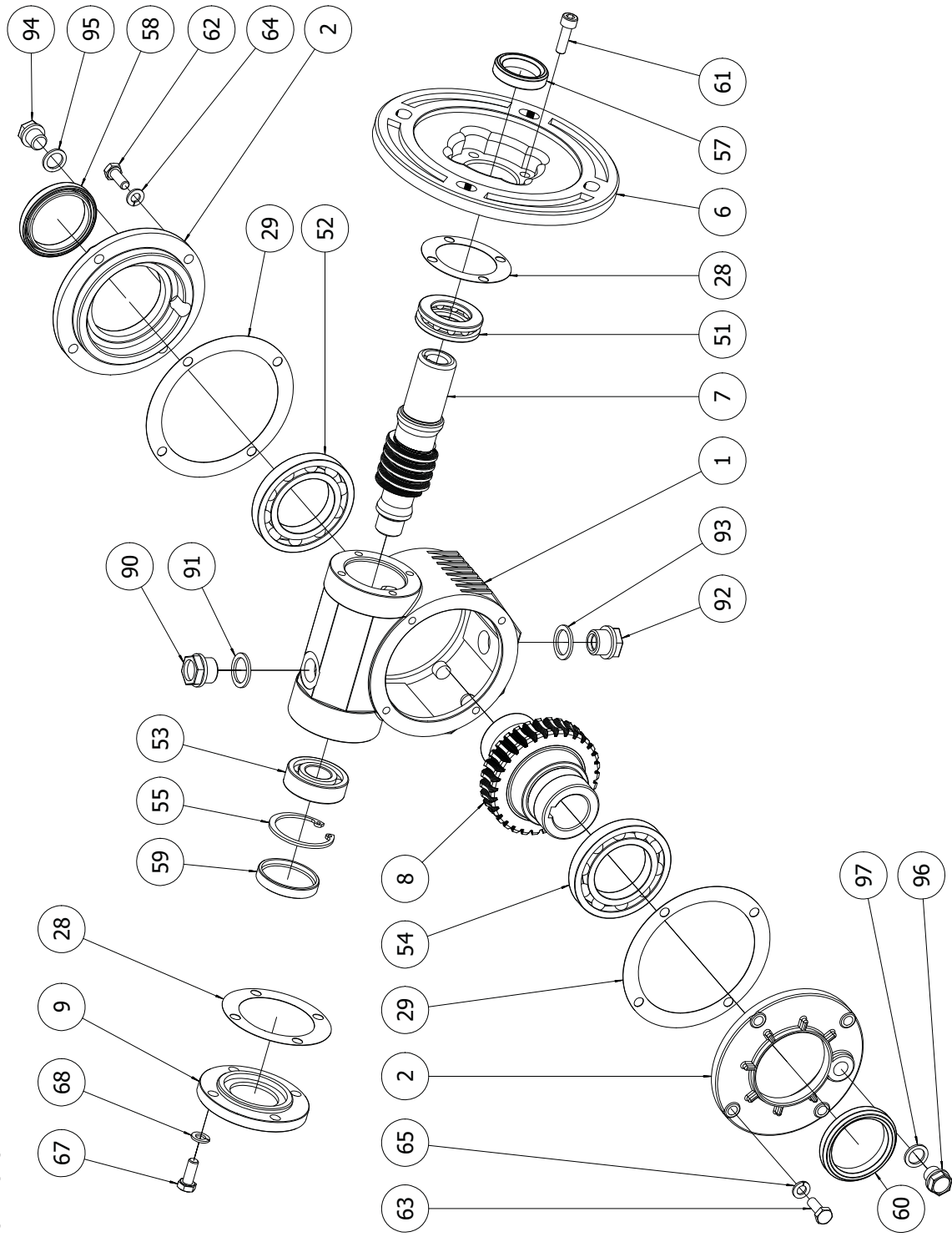

RV
 n° compl. 01001.2
 13/03/05

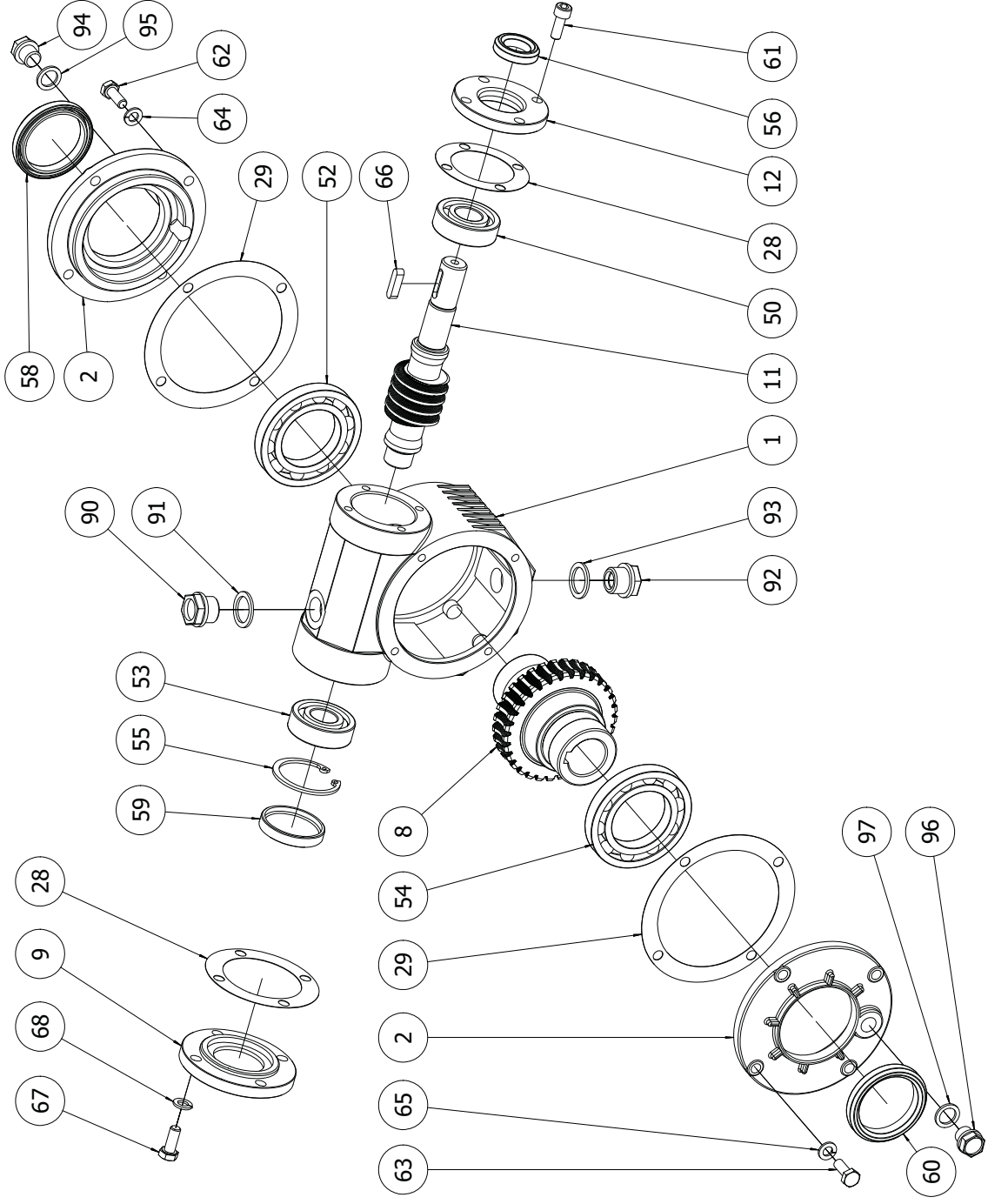

MRV/RV WITH OUTPUT FLANGE
n° compl. 01001.3
13/03/05

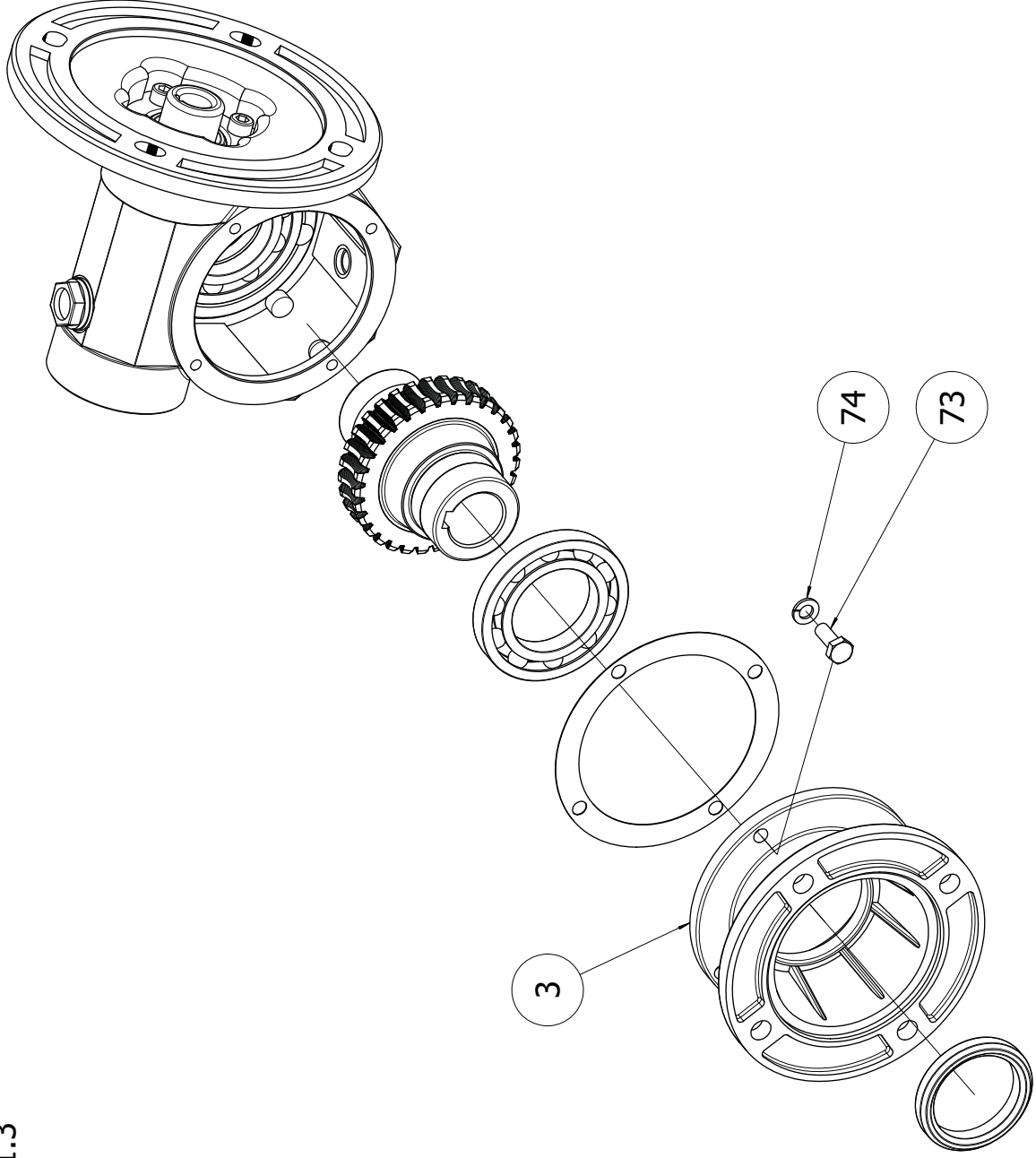

MRV/RV WITH PENDULAR FLANGE

n° compl. 01001.4

13/03/05

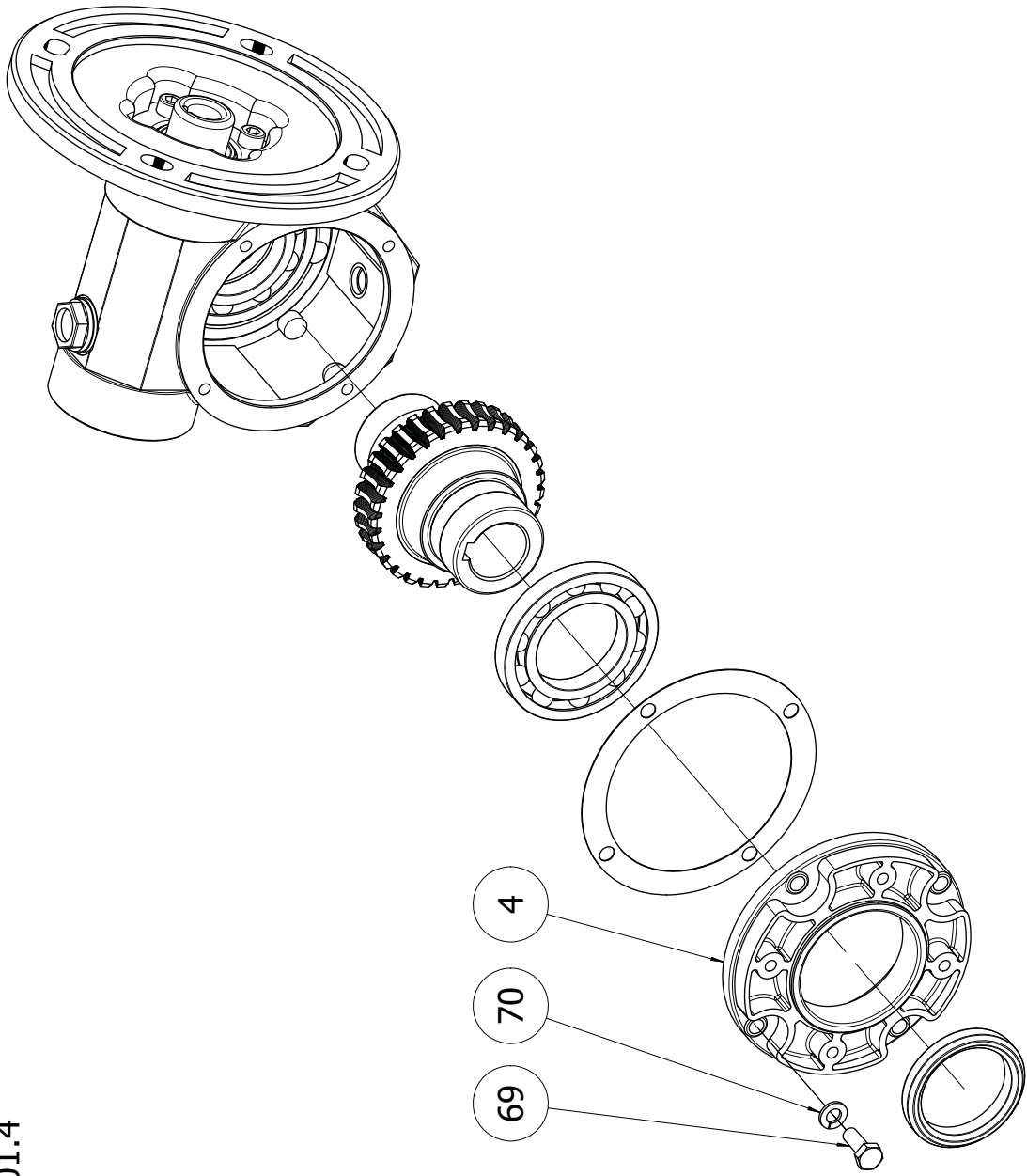

MRV/RV WITH FEET
n° compl. 01001.5
13/03/05

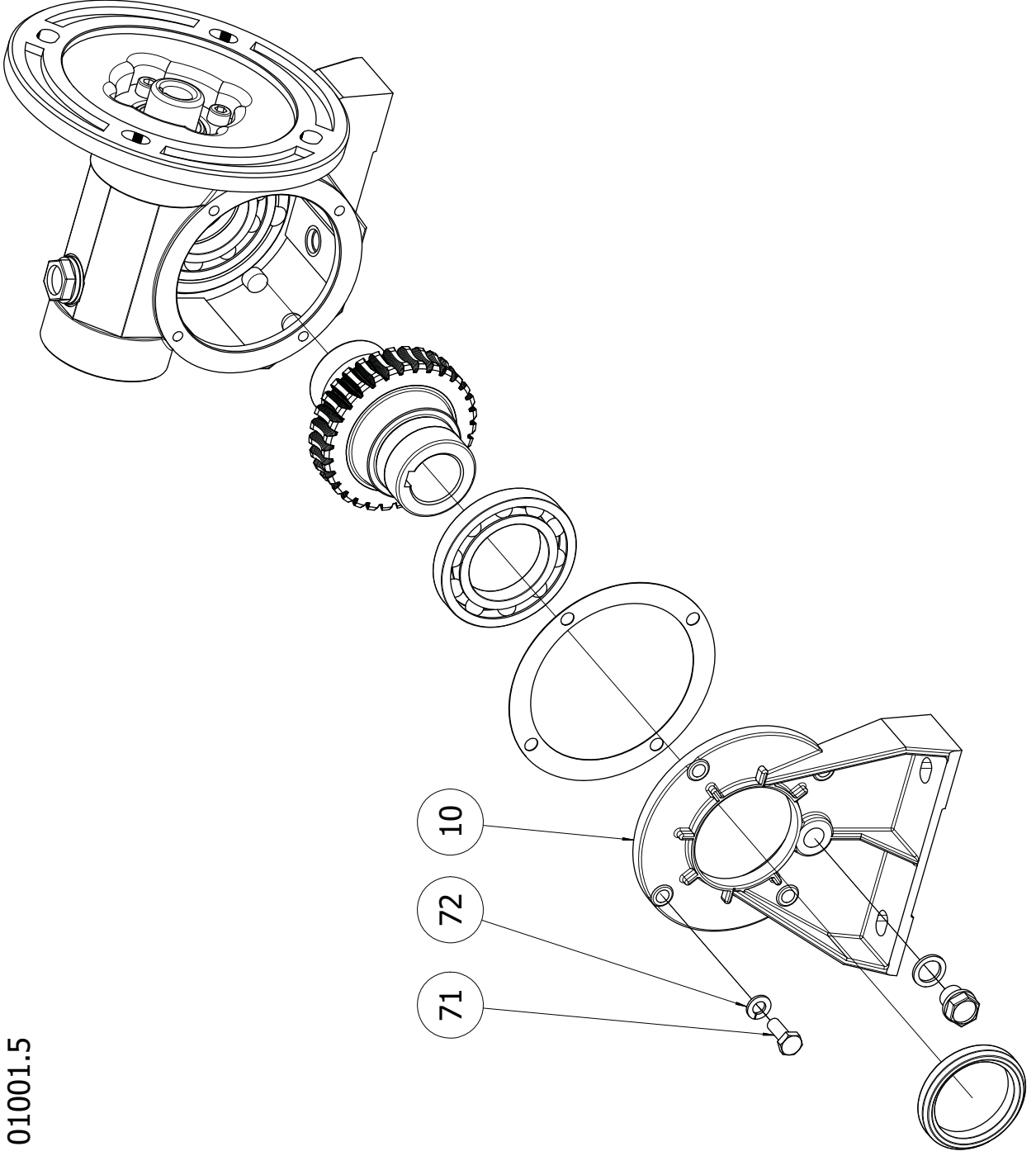

MRV/RV OUTPUT SHAFTS

n° compl. 01001.6

13/03/05

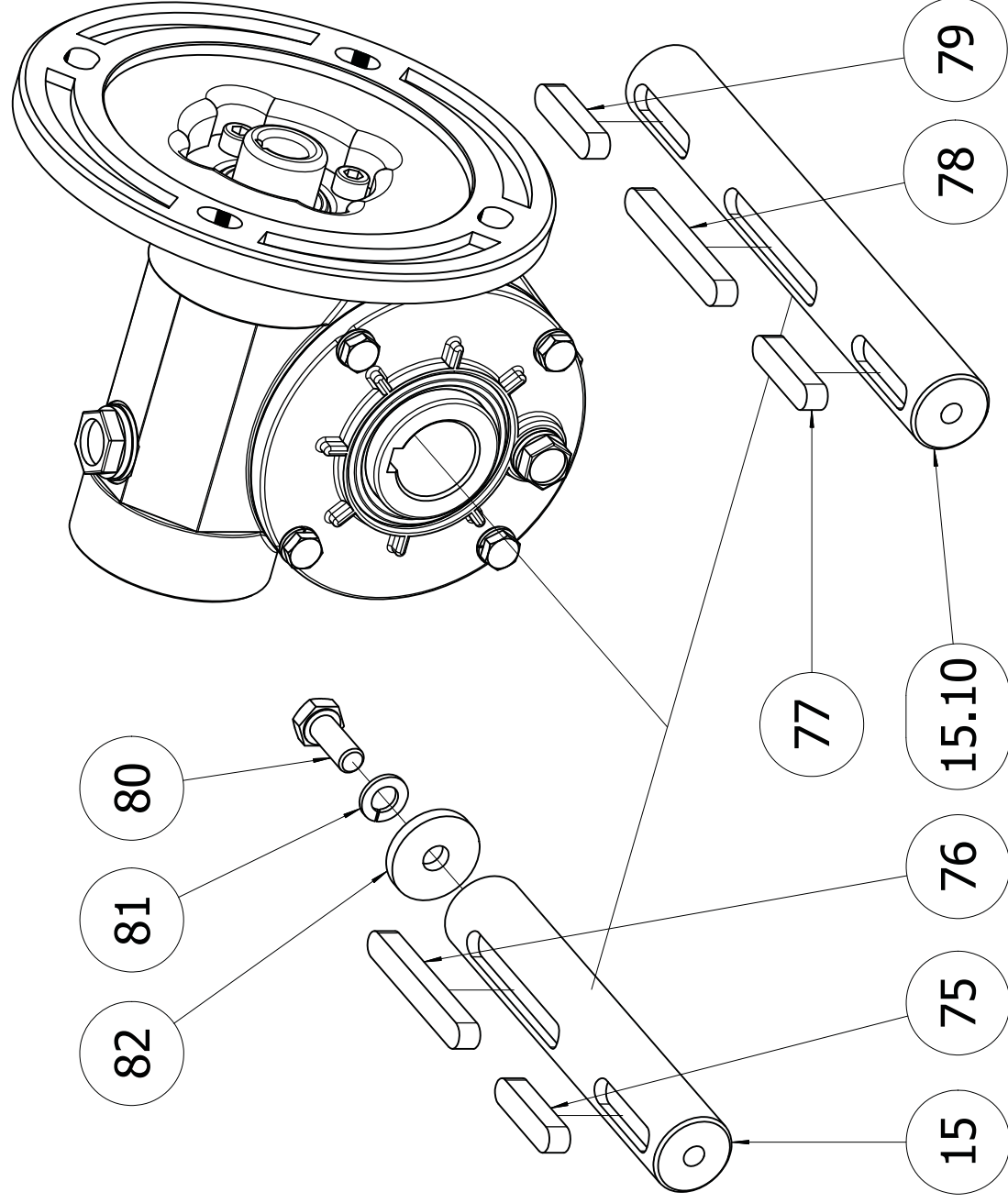

MRV/RV TORQUE ARM
n° compl. 01001.7
13/03/05

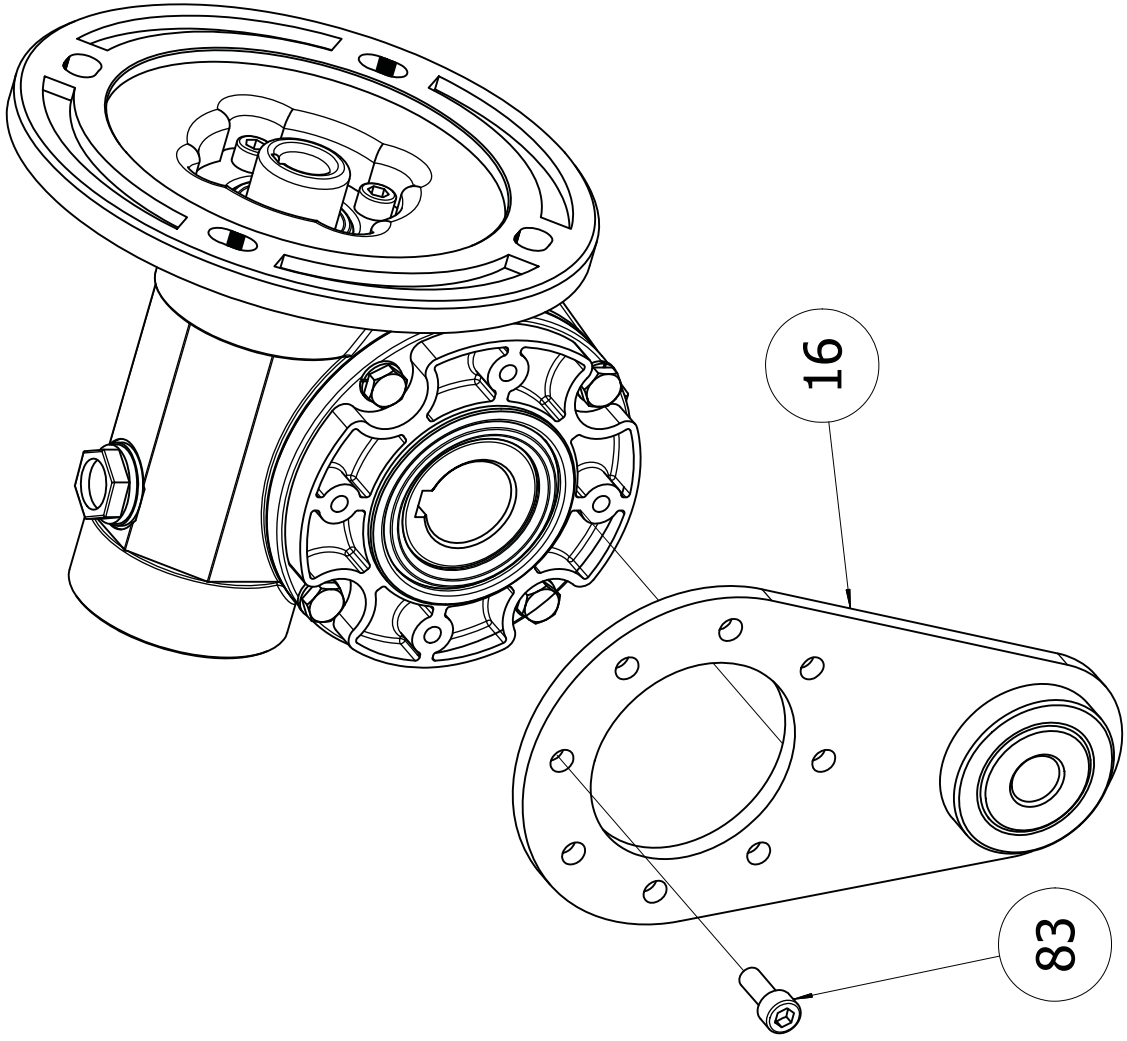

MRV/RV
TABLE 1
Update 11/03/2005

| Prog. Pos. | Denomination | P/C | Size (component for gear size) | | | | | | | | | | | | | |
|------------|---------------------------|-----|--------------------------------|------------|------------|------------|------------|------------|------------|------------|--|--|--|--|--|--|
| | | | 05 | 10 | 20 | 30 | 40 | 50 | 60 | 70 | | | | | | |
| 01 | Casing | P | 0100501 | 0101001 | 0102001 | 0103001 | 0104001 | 0105001 | 0106001 | 0107001 | | | | | | |
| 01 | Lateral cover | P | 0100502 | 0101002 | 0102002 | 0103002 | 0104002 | 0105002 | 0106002 | 0107002 | | | | | | |
| 01 | Output flange | P | 0100503 | 0101003 | 0102003 | 0103003 | 0104003 | 0105003 | 0106003 | 0107003 | | | | | | |
| 01 | Pendular flange | P | 0100504 | 0101004 | 0102004 | 0103004 | 0104004 | 0105004 | 0106004 | 0107004 | | | | | | |
| 01 | Motor flange | P | 0100506 | 0101006 | 0102006 | 0103006 | 0104006 | 0105006 | 0106006 | 0107006 | | | | | | |
| 01 | Worm shaft PAM | P | 0100507 | 0101007 | 0102007 | 0103007 | 0104007 | 0105007 | 0106007 | 0107007 | | | | | | |
| 01 | Worm wheel | P | 0100508 | 0101008 | 0102008 | 0103008 | 0104008 | 0105008 | 0106008 | 0107008 | | | | | | |
| 01 | Closed cover | P | - | - | - | - | 0104009 | 0105009 | 0106009 | 0107009 | | | | | | |
| 01 | Feet | P | 0100510 | 0101010 | 0102010 | 0103010 | 0104010 | 0105010 | 0106010 | 0107010 | | | | | | |
| 01 | Worm shaft RV | P | 0100511 | 0101011 | 0102011 | 0103011 | 0104011 | 0105011 | 0106011 | 0107011 | | | | | | |
| 01 | Cover | P | 0100512 | 0101012 | 0102012 | 0103012 | 0104012 | 0105012 | 0106012 | 0107012 | | | | | | |
| 01 | Output shaft | P | 0100515 | 0101015 | 0102015 | 0103015 | 0104015 | 0105015 | 0106015 | 0107015 | | | | | | |
| 01 | 15,10 Double output shaft | P | 0100515.10 | 0101015.10 | 0102015.10 | 0103015.10 | 0104015.10 | 0105015.10 | 0106015.10 | 0107015.10 | | | | | | |
| 01 | Torque arm | P | 0100516 | 0101016 | 0102016 | 0103016 | 0104016 | 0105016 | 0106016 | 0107016 | | | | | | |
| 01 | Gasket | P | 0100528 | 0101028 | 0102028 | 0103028 | 0104028 | 0105028 | 0106028 | 0107028 | | | | | | |
| 01 | Gasket | P | 0100529 | 0101029 | 0102029 | 0103029 | 0104029 | 0105029 | 0106029 | 0107029 | | | | | | |
| - | Bearing 1 on worm shaft | C | 6202 | 6203 | 30204 | 30205 | 30203 | 30207 | 30307 | 30211 | | | | | | |
| - | Bearing 1 on worm shaft | C | 51104 | 51105 | 51106 | 51107 | 32007 | 32009 | 32010 | 32013 | | | | | | |
| - | Bearing 2 on worm shaft | C | 16006 | 16008 | 16009 | 16009 | 6010 | 6011 | 6213 | 6018 | | | | | | |
| - | Bearing 1 on worm wheel | C | 6202 | 6203 | 30204 | 30205 | 30206 | 30207 | 30307 | 30211 | | | | | | |
| - | Bearing 2 on worm wheel | C | 16006 | 16008 | 16009 | 16009 | 6010 | 6011 | 6213 | 6018 | | | | | | |
| - | Seeger UNI 7437 | C | 135 | 140 | 147 | 152 | - | - | - | - | | | | | | |
| - | Oil seal ring DIN 3760 | C | 15x30x7 | 17x28x7 | 20x30x8 | 25x35x8 | 30x45x8 | 35x47x8 | 35x47x8 | 55x70x8 | | | | | | |
| - | Oil seal ring DIN 3760 | C | 20x30x8 | 25x35x8 | 30x40x8 | 35x45x8 | 35x47x8 | 45x60x8 | 50x65x8 | 65x90x10 | | | | | | |
| - | Oil seal ring DIN 3760 | C | 30x45x8 | 40x52x8 | 45x60x8 | 45x65x10 | 50x70x10 | 55x70x8 | 65x90x10 | 90x120x12 | | | | | | |
| - | Cover RCA | C | 35x7 | 40x7 | 47x7 | 52x7 | - | - | - | - | | | | | | |
| - | Oil seal ring DIN 3760 | C | 30x45x8 | 40x52x8 | 45x60x8 | 45x65x10 | 50x70x10 | 55x70x8 | 65x90x10 | 90x120x12 | | | | | | |
| - | Screw DIN EN 24014 | C | M5x20 | M6x22 | M6x22 | M8x25 | M8x25 | M8x25 | M8x25 | M8x30 | | | | | | |
| - | Screw DIN EN 24014 | C | M5x16 | M6x18 | M6x18 | M6x18 | M6x20 | M8x22 | M8x25 | M10x30 | | | | | | |
| - | Screw DIN EN 24014 | C | M5x16 | M6x18 | M6x18 | M6x18 | M6x20 | M8x22 | M8x25 | M10x30 | | | | | | |
| - | Washer DIN 128 | C | Dn 5 | Dn 6 | Dn 6 | Dn 6 | Dn 6 | Dn 8 | Dn 8 | Dn 10 | | | | | | |
| - | Washer DIN 128 | C | Dn 5 | Dn 6 | Dn 6 | Dn 6 | Dn 6 | Dn 8 | Dn 8 | Dn 10 | | | | | | |
| - | Key DIN 6885 | C | 5x5x20 | 5x5x20 | 6x6x25 | 6x6x30 | 8x7x35 | 8x7x45 | 10x8x60 | 10x8x60 | | | | | | |
| - | Screw DIN EN 24014 | C | - | - | - | - | M8x22 | M8x22 | M8x25 | M8x30 | | | | | | |
| - | Washer DIN 128 | C | - | - | - | - | Dn 8 | Dn 8 | Dn 8 | Dn 8 | | | | | | |
| - | Screw DIN EN 24014 | C | M5x16 | M6x18 | M6x18 | M6x18 | M6x20 | M8x22 | M8x25 | M10x30 | | | | | | |

| | | | | | | | | | | | | | |
|---|----|-----------------------|---|------------|------------|------------|-------------|-------------|-------------|-------------|-------------|-------------|---------|
| - | 70 | Washer DIN 128 | C | Dn 5 4 | Dn 6 4 | Dn 6 8 | Dn 6 8 | Dn 6 8 | Dn 8 8 | Dn 8 8 | Dn 8 8 | Dn 8 8 | Dn 10 8 |
| - | 71 | Screw DIN EN 24014 | C | M5x16 4 | M6x18 4 | M6x18 8 | M6x20 8 | M6x20 8 | M8x22 8 | M8x25 8 | M10x30 8 | M10x30 8 | |
| - | 72 | Washer DIN 128 | C | Dn 5 4 | Dn 6 4 | Dn 6 8 | Dn 6 8 | Dn 6 8 | Dn 8 8 | Dn 8 8 | Dn 10 8 | Dn 10 8 | |
| - | 73 | Screw DIN EN 24014 | C | M5x16 4 | M6x18 4 | M6x18 8 | M6x20 8 | M6x20 8 | M8x22 8 | M8x25 8 | M10x30 8 | M10x30 8 | |
| - | 74 | Washer DIN 128 | C | Dn 5 4 | Dn 6 4 | Dn 6 8 | Dn 6 8 | Dn 6 8 | Dn 8 8 | Dn 8 8 | Dn 10 8 | Dn 10 8 | |
| - | 75 | Key DIN 6885 | C | 6x6x30 1 | 6x6x30 1 | 8x7x40 1 | 10x8x50 1 | 10x8x50 1 | 10x8x50 1 | 12x8x60 1 | 16x10x90 1 | 16x10x90 1 | |
| - | 76 | Key DIN 6885 | C | 6x6x50 1 | 6x6x60 1 | 8x7x80 1 | 10x8x90 1 | 10x8x90 1 | 10x8x90 1 | 12x8x100 1 | 16x10x120 1 | 16x10x120 1 | |
| - | 77 | Key DIN 6885 | C | 6x6x30 1 | 6x6x30 1 | 8x7x40 1 | 10x8x50 1 | 10x8x50 1 | 10x8x50 1 | 12x8x60 1 | 16x10x90 1 | 16x10x90 1 | |
| - | 78 | Key DIN 6885 | C | 6x6x50 1 | 6x6x60 1 | 8x7x80 1 | 10x8x90 1 | 10x8x90 1 | 10x8x90 1 | 12x8x100 1 | 16x10x120 1 | 16x10x120 1 | |
| - | 79 | Key DIN 6885 | C | 6x6x30 1 | 6x6x30 1 | 8x7x40 1 | 10x8x50 1 | 10x8x50 1 | 10x8x50 1 | 12x8x60 1 | 16x10x90 1 | 16x10x90 1 | |
| - | 80 | Screw DIN EN 24014 | C | M6x18 1 | M6x18 1 | M8x20 1 | M10x25 1 | M10x25 1 | M10x25 1 | M10x30 1 | M12x45 1 | M12x45 1 | |
| - | 81 | Washer DIN 128 | C | Dn 6 1 | Dn 6 1 | Dn 8 1 | Dn 10 1 | Dn 10 1 | Dn 10 1 | Dn 10 1 | Dn 12 1 | Dn 12 1 | |
| - | 82 | Washer | C | 6,2x28x4 1 | 6,2x28x4 1 | 8,2x40x4 1 | 10,5x56x6 1 | 10,5x56x6 1 | 10,5x56x6 1 | 10,5x56x6 1 | 12,5x70x6 1 | 12,5x70x6 1 | |
| - | 83 | Screw DIN EN ISO 4762 | C | M6x14 1 | M6x14 1 | M8x18 1 | M10x22 1 | M10x22 1 | M12x20 1 | M12x18 1 | M14x22 1 | M14x22 1 | |
| - | 90 | Filling plug | C | 3/8" Gas 1 | 3/8" Gas 1 | 3/8" Gas 1 | 3/8" Gas 1 | 3/8" Gas 1 | 3/8" Gas 1 | 3/8" Gas 1 | 3/8" Gas 1 | 3/8" Gas 1 | |
| - | 91 | Gasket | C | 3/8" Gas 1 | 3/8" Gas 1 | 3/8" Gas 1 | 3/8" Gas 1 | 3/8" Gas 1 | 3/8" Gas 1 | 3/8" Gas 1 | 3/8" Gas 1 | 3/8" Gas 1 | |
| - | 92 | Filling plug | C | - | - | 3/8" Gas 1 | 3/8" Gas 1 | 3/8" Gas 1 | 3/8" Gas 1 | 3/8" Gas 1 | 3/8" Gas 1 | 3/8" Gas 1 | |
| - | 93 | Gasket | C | - | - | 3/8" Gas 1 | 3/8" Gas 1 | 3/8" Gas 1 | 3/8" Gas 1 | 3/8" Gas 1 | 3/8" Gas 1 | 3/8" Gas 1 | |
| - | 94 | Filling plug | C | - | - | 3/8" Gas 1 | 3/8" Gas 1 | 3/8" Gas 1 | 3/8" Gas 1 | 3/8" Gas 1 | 3/8" Gas 1 | 3/8" Gas 1 | |
| - | 95 | Gasket | C | - | - | 3/8" Gas 1 | 3/8" Gas 1 | 3/8" Gas 1 | 3/8" Gas 1 | 3/8" Gas 1 | 3/8" Gas 1 | 3/8" Gas 1 | |
| - | 96 | Filling plug | C | - | - | 3/8" Gas 1 | 3/8" Gas 1 | 3/8" Gas 1 | 3/8" Gas 1 | 3/8" Gas 1 | 3/8" Gas 1 | 3/8" Gas 1 | |
| - | 97 | Gasket | C | - | - | 3/8" Gas 1 | 3/8" Gas 1 | 3/8" Gas 1 | 3/8" Gas 1 | 3/8" Gas 1 | 3/8" Gas 1 | 3/8" Gas 1 | |

Size (specifies component for gear size)

For version realized according to ATEX specification, it will follow the following:
 Installation of the special ATEX plate
 Installation of irreversible temperature indicators
 Using of metal plugs
 Using of oil seal rings in Viton

ATEX certification is available for the following sizes: 40, 50, 60, 70.

- Legend:
 Prog. Project number
 Pos. Component position
 P/C Product component [P] or commercial [C]
 Q Quantity

7.0 MRV/RV MOUNTING POSITIONS
n° compl. 01001.8
13/03/05

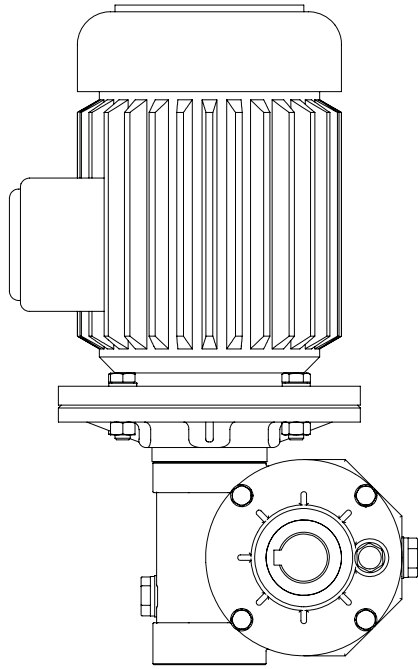

B 3

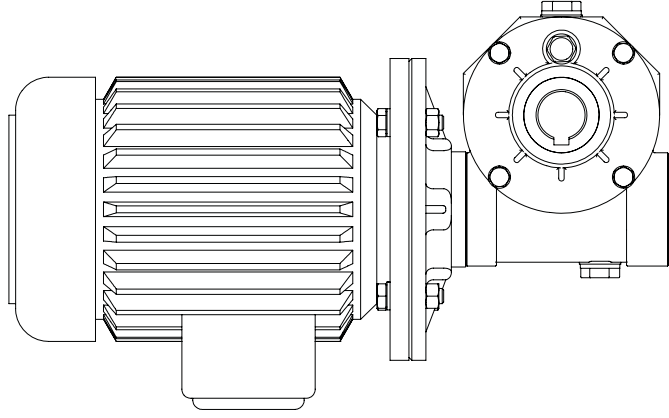

B 6

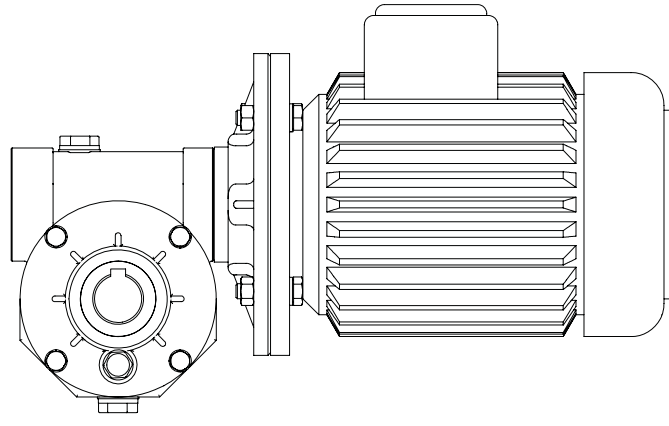

B 7

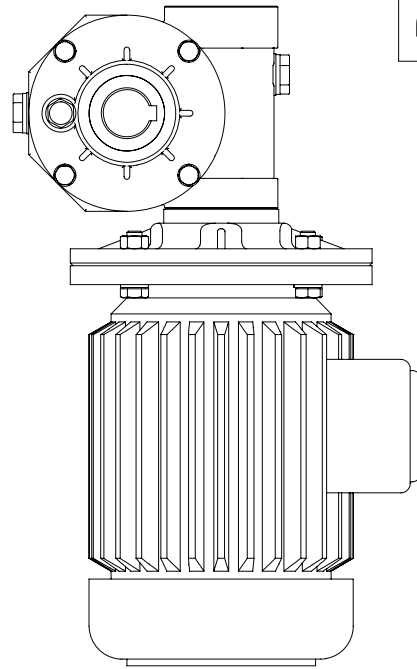

B 8

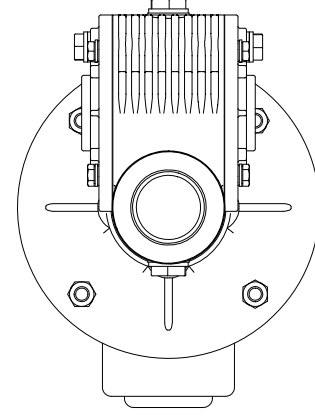

V 5

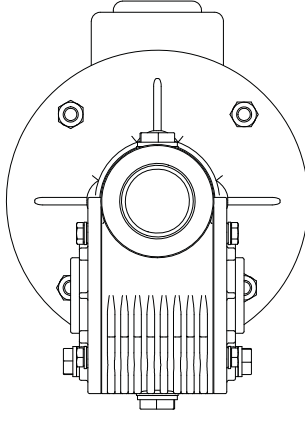

V 6

8.0 SPARES TABLE

GEARED MOTOR REDUCERS MV/V

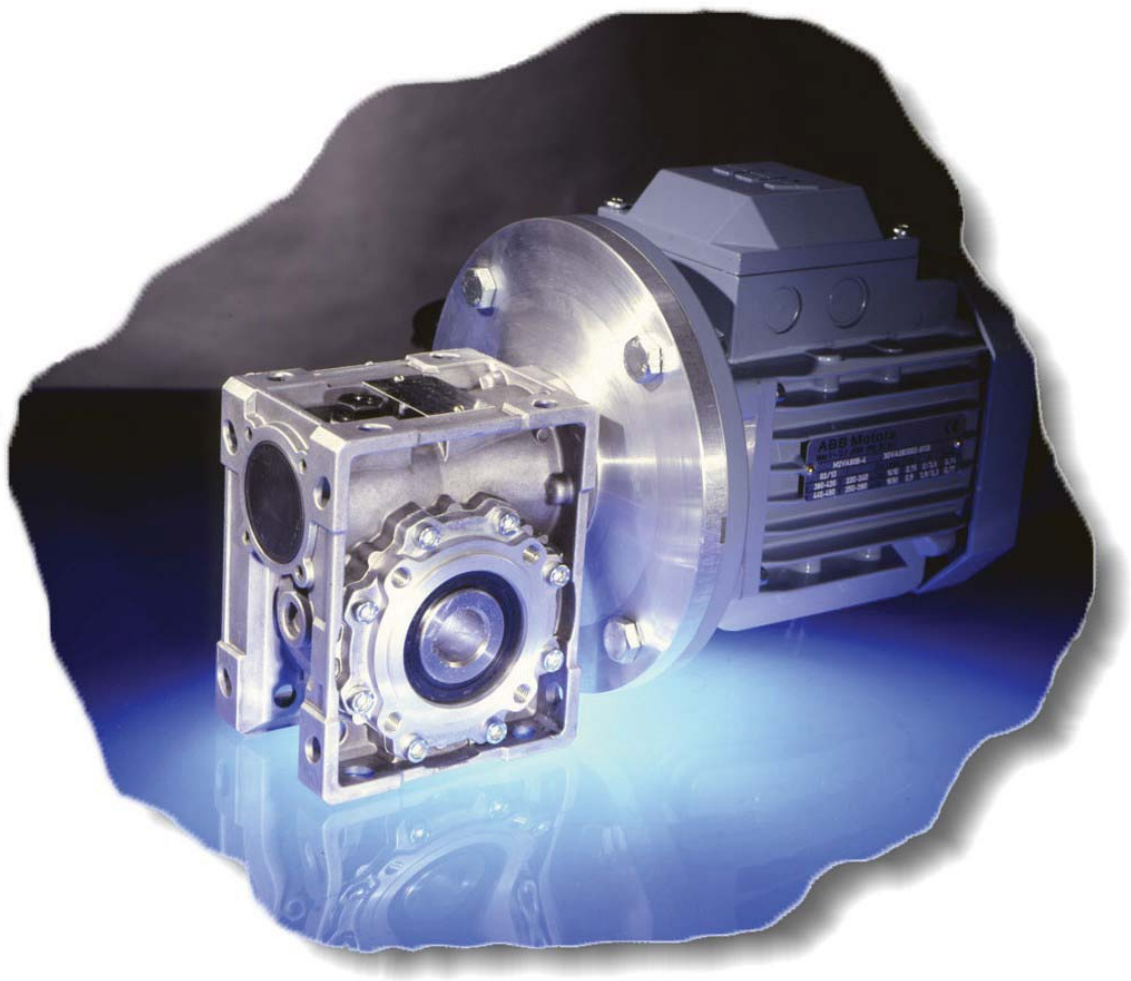

MV PAM
n° compl. 40001.1
13/03/05

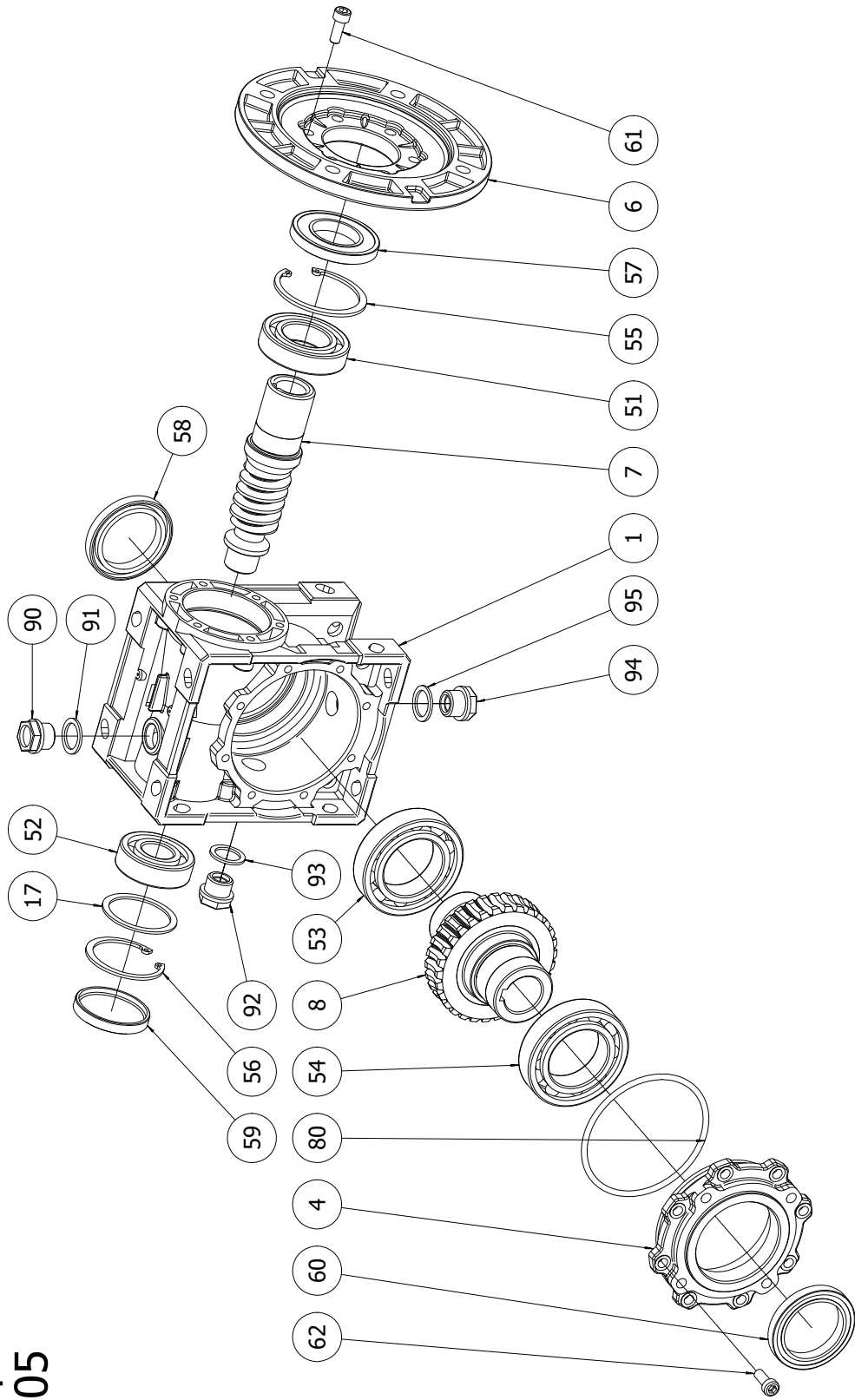

V
 n° compl. 40001.2
 13/03/05

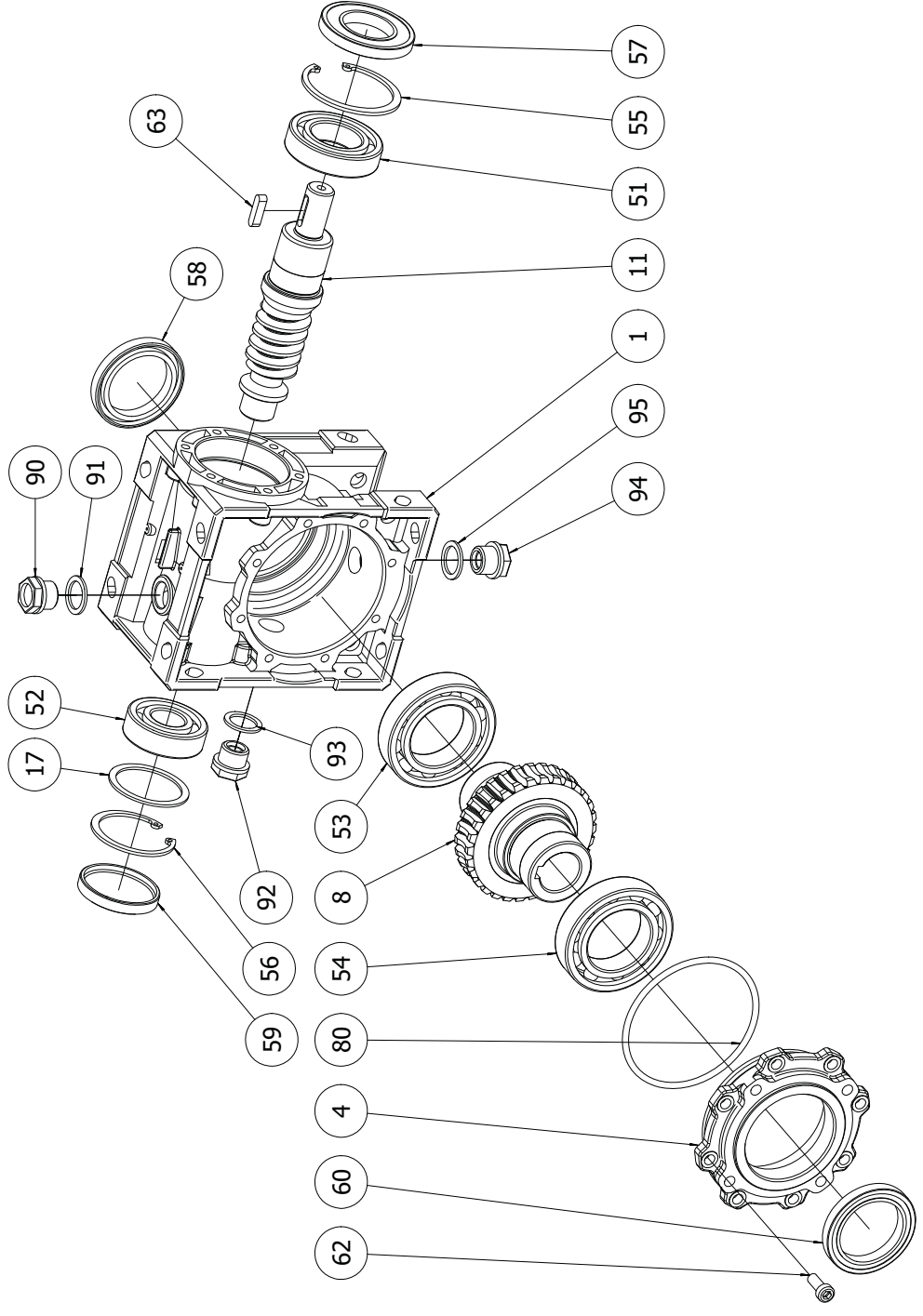

MV/V WITH OUTPUT FLANGE
n° compl. 40001.3
13/03/05

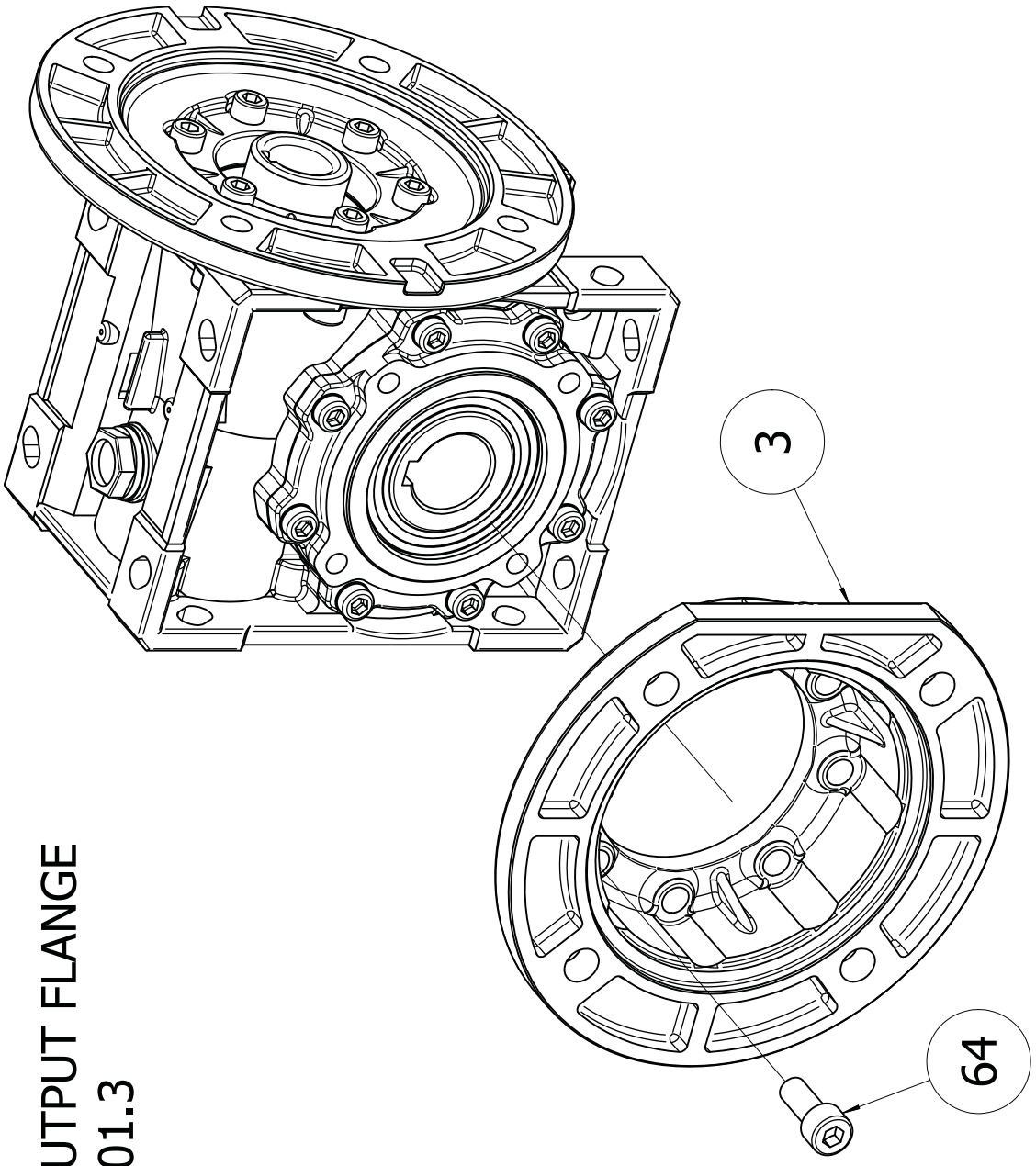

MV/V OUTPUT SHAFTS
n° compl. 40001.5
13/03/05

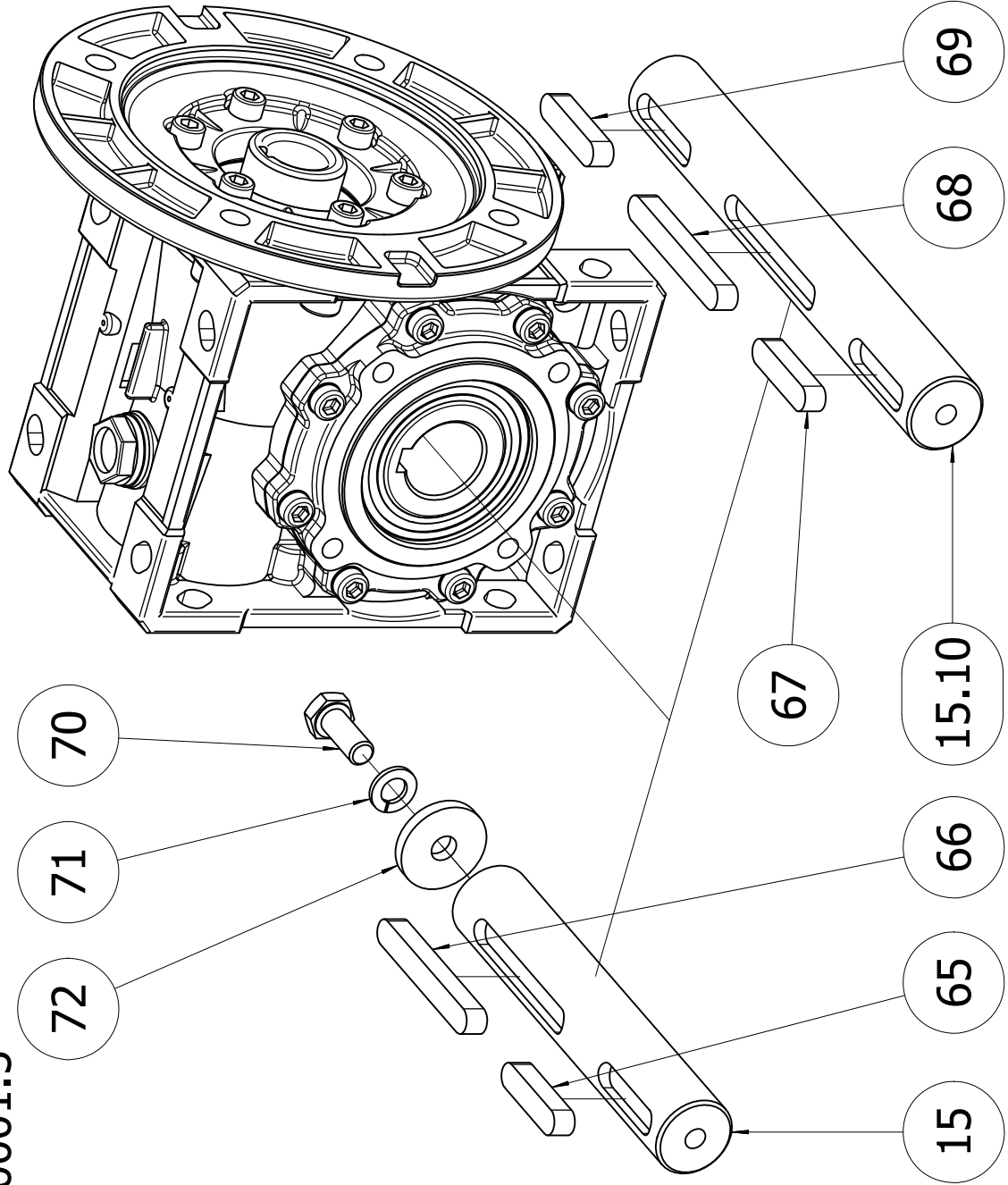

MV/V TORQUE ARM
n° compl. 40001.4
13/03/05

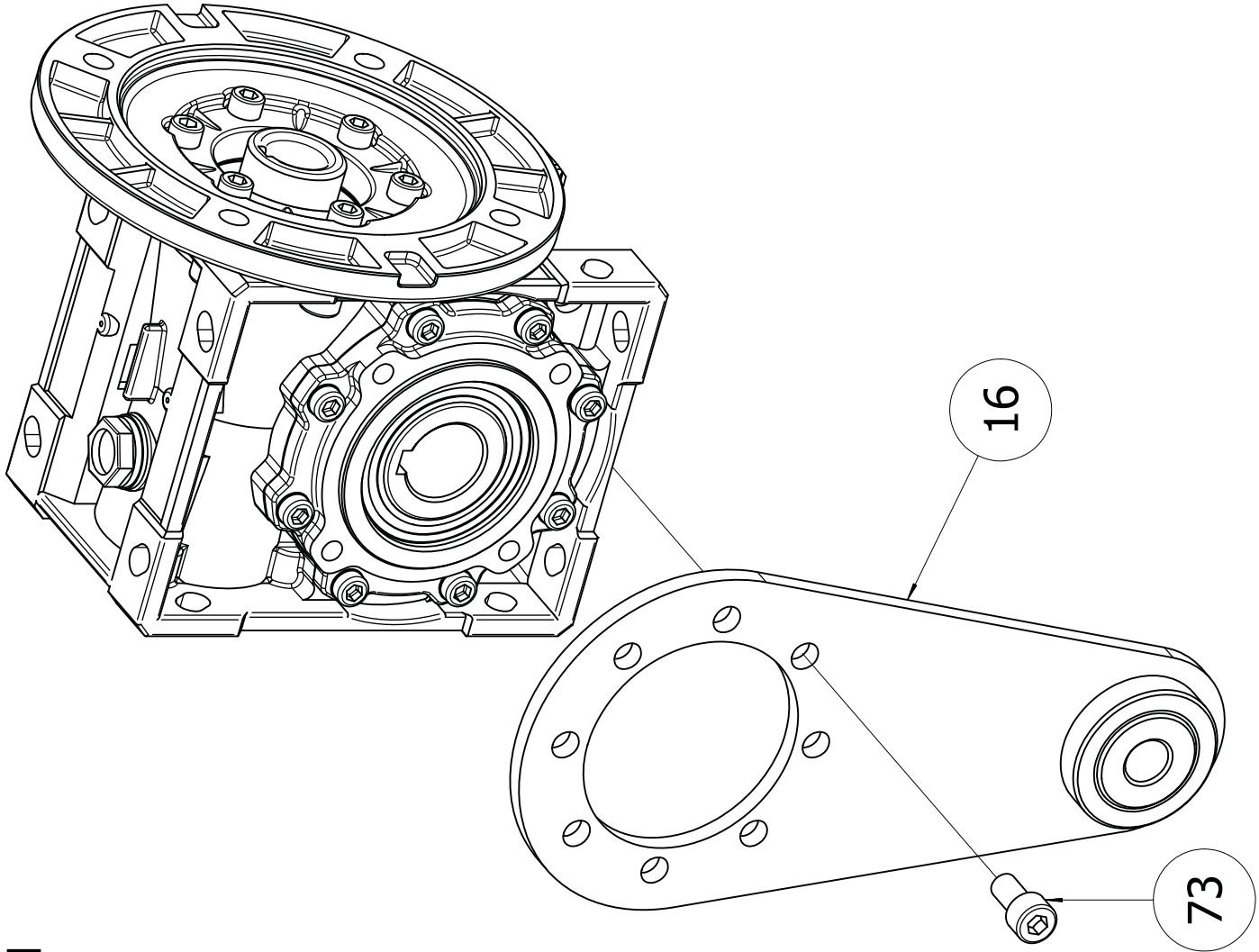

TABLE 1
Update 20/06/2006

| | | Size (component for gear size) | | | | | | | | | | |
|-------|-------|--------------------------------|-----|----------|-----------|------------|------------|------------|------------|------------|------------|---|
| Prog. | Pos. | Denomination | P/C | 25 | 30 | 40 | 50 | 63 | 75 | 90 | 110 | Q |
| 40 | 1 | Casing | P | 0300201 | 4003001 | 4004001 | 4005001 | 4006301 | 4007501 | 4009001 | 4011001 | 1 |
| 40 | 3 | Output flange | P | - | 0300303 | 4004003 | 4005003 | 4006303 | 4007503 | 4009003 | 4011003 | 1 |
| 40 | 4 | Pendular flange | P | - | - | 4004004 | 4005004 | 4006304 | 4007504 | 4009004 | 4011004 | 1 |
| 40 | 6 | Motor flange | P | - | - | 4005006 | 4005006 | 4007506 | 4007506 | 4011006 | 4011006 | 1 |
| 40 | 7 | Worm shaft PAM | P | 0300206 | 0100506 | 4004007 | 4005007 | 4006307 | 4007507 | 4009007 | 4011007 | 1 |
| 40 | 8 | Worm wheel | P | 0300207 | 0300307 | 4004008 | 4005008 | 4006308 | 4007508 | 4009008 | 4011008 | 1 |
| 40 | 11 | Worm shaft V | P | 0300208 | 0300308 | 4004011 | 4005011 | 4006311 | 4007511 | 4009011 | 4011011 | 1 |
| 40 | 15 | Output shaft | P | 0300211 | 0300311 | 4004015 | 4005015 | 4006315 | 4007515 | 4009015 | 4011015 | 1 |
| 40 | 15,10 | Double output shaft | P | 0300215 | 0300315 | 4004015,10 | 4005015,10 | 4006315,10 | 4007515,10 | 4009015,10 | 4011015,10 | 1 |
| 40 | 16 | Torque arm | P | - | 0300316 | 0100516 | 0102016 | 4006316 | 0103016 | 0104016 | 0105016 | 1 |
| 40 | 17 | Spacer | P | - | - | 4004017 | 4005017 | 4006317 | 4007517 | 4007517 | 4011017 | 1 |
| - | 51 | Bearing 1 on worm shaft | C | 61903 | ** 6202 | 6005 | 6006 | 32007 | 32008 | 32008 | 32010 | 1 |
| - | 52 | Bearing 2 on worm shaft | C | 6000 | 6001 | 6203 | 6204 | 30205 | 30206 | 32206 | 32207 | 1 |
| - | 53 | Bearing 1 on worm wheel | C | 16004 | 16006 | 6006 | 6008 | 6009 | 6010 | 6012 | 6013 | 1 |
| - | 54 | Bearing 2 on worm wheel | C | *16004 | *** 16006 | 6006 | 6008 | 6009 | 6010 | 6012 | 6013 | 1 |
| - | 55 | Seeger UNI 7437 | C | 130 | 135 | 147 | 155 | 162 | 168 | 168 | 180 | 1 |
| - | 56 | Seeger UNI 7437 | C | 126 | 128 | 140 | 147 | 152 | 162 | 162 | 172 | 1 |
| - | 57 | Oil seal ring DIN 3760 | C | 17x28x7 | 18x30x7 | 25x47x7 | 30x55x7 | 35x62x7 | 40x68x7 | 40x68x10 | 50x80x10 | 1 |
| - | 58 | Oil seal ring DIN 3760 | C | 20x30x8 | 30x40x7 | 30x42x7 | 40x56x7 | 45x65x10 | 50x68x8 | 60x85x8 | 65x85x10 | 1 |
| - | 59 | Cover RCA | C | 26x7 | 28x7 | 40x7 | 47x7 | 52x7 | 62x7 | 62x7 | 72x10 | 1 |
| - | 60 | Oil seal ring DIN 3760 | C | 20x42x7 | 30x55x7 | 30x42x7 | 40x56x7 | 45x65x10 | 50x68x8 | 60x85x8 | 65x85x10 | 1 |
| - | 61 | Screw DIN EN ISO 4762 | C | M5x14 | M5x20 | M6x20 | M6x20 | M8x20 | M8x20 | M8x22 | M10x25 | 6 |
| - | 62 | Screw DIN 7984 (ribassata) | C | - | - | M6x16 | M6x16 | M8x16 | M8x16 | M8x20 | M8x22 | 8 |
| - | 63 | Key DIN 6885 | C | 3x3x15 | 4x4x18 | 5x5x20 | 5x5x20 | 6x6x30 | 6x6x30 | 8x7x35 | 8x7x45 | 1 |
| - | 64 | Screw DIN EN ISO 4762 | C | - | M5x16 | M6x20 | M8x20 | M8x22 | M8x22 | M10x25 | M10x25 | 8 |
| - | 65 | Key DIN 6885 | C | 4x4x15 | 5x5x20 | 6x6x30 | 8x7x35 | 8x7x40 | 8x7x45 | 10x8x50 | 12x8x60 | 1 |
| - | 66 | Key DIN 6885 | C | 4x4x30 | 5x5x30 | 6x6x50 | 8x7x60 | 8x7x80 | 8x7x80 | 10x8x90 | 12x8x100 | 1 |
| - | 67 | Key DIN 6885 | C | 4x4x15 | 5x5x20 | 6x6x30 | 8x7x35 | 8x7x40 | 8x7x45 | 10x8x50 | 12x8x60 | 1 |
| - | 68 | Key DIN 6885 | C | 4x4x30 | 5x5x30 | 6x6x50 | 8x7x60 | 8x7x80 | 8x7x80 | 10x8x90 | 12x8x100 | 1 |
| - | 69 | Key DIN 6885 | C | 4x4x15 | 5x5x20 | 6x6x30 | 8x7x35 | 8x7x40 | 8x7x45 | 10x8x50 | 12x8x60 | 1 |
| - | 70 | Screw DIN EN 24014 | C | M4x12 | M5x16 | M6x18 | M8x22 | M8x22 | M8x22 | M10x25 | M10x25 | 1 |
| - | 71 | Washer DIN 128 | C | Dn 4 | Dn 5 | Dn 6 | Dn 8 | Dn 8 | Dn 8 | Dn 10 | Dn 10 | 1 |
| - | 72 | Washer | C | 5,2x16x3 | 5,2x20x3 | 6,2x28x4 | 6,2x28x4 | 8,2x28x4 | 8,2x40x4 | 10,5x56x6 | 10,5x56x6 | 1 |

| | | | | | | | | | | | | | | | | | | | | |
|---|----|-----------------------|---|---|---|----------|---|----------|---|----------|---|----------|---|----------|----------|----------|----------|----------|----------|---|
| - | 73 | Screw DIN EN ISO 4762 | C | - | - | M5x12 | 4 | M6x14 | 4 | M8x16 | 4 | M8x16 | 8 | M8x20 | 8 | M10x22 | 8 | M10x22 | 8 | |
| - | 80 | Gasket | C | - | - | - | - | 3256 | 1 | 4400 | 1 | 4400 | 1 | 4487 | 1 | 4600 | 1 | 4750 | 1 | |
| - | 90 | Filling plug | C | - | - | - | - | 3/8" Gas | 1 | 3/8" Gas | 1 | 3/8" Gas | 1 | 3/8" Gas | 1 | 3/8" Gas | 1 | 3/8" Gas | 1 | |
| - | 91 | Gasket | C | - | - | - | - | 3/8" Gas | 1 | 3/8" Gas | 1 | 3/8" Gas | 1 | 3/8" Gas | 1 | 3/8" Gas | 1 | 3/8" Gas | 1 | |
| - | 92 | Filling plug | C | - | - | - | - | - | - | - | - | - | - | - | - | 3/8" Gas | 1 | 3/8" Gas | 1 | |
| - | 93 | Gasket | C | - | - | - | - | - | - | - | - | - | - | - | - | 3/8" Gas | 1 | 3/8" Gas | 1 | |
| - | 94 | Filling plug | C | - | - | 1/4" Gas | 1 | - | - | - | - | - | - | - | 3/8" Gas | 1 | 3/8" Gas | 1 | 3/8" Gas | 1 |
| - | 95 | Gasket | C | - | - | 1/4" Gas | 1 | - | - | - | - | - | - | - | 3/8" Gas | 1 | 3/8" Gas | 1 | 3/8" Gas | 1 |

| 25 | Q | 30 | Q | 40 | Q | 50 | Q | 63 | Q | 75 | Q | 90 | Q | 110 | Q |
|--|---|----|---|----|---|----|---|----|---|----|---|----|---|-----|---|
| Size (specified component for gear size) | | | | | | | | | | | | | | | |

- * Installed together with seeger UNI7437 I 42
- ** For version MV it's installed one bearing 6003 together with seeger UNI7435 E 17
- *** Installed together with seeger UNI7437 I 55

For version realized according to ATEX specification, it will follow the following:

- Installation of the special ATEX plate
- Installation of irreversible temperature indicators
- Using of special plugs
- Using of oil seal rings in Viton

Legend:

- Prog. Project number
- Pos. Component position
- P/C Product component [P] or commercial [C]
- Q Quantity
- * Verify the below notes

9.0 MOUNTING POSITIONS MV/V
n° compl. 40001.6
13/03/05

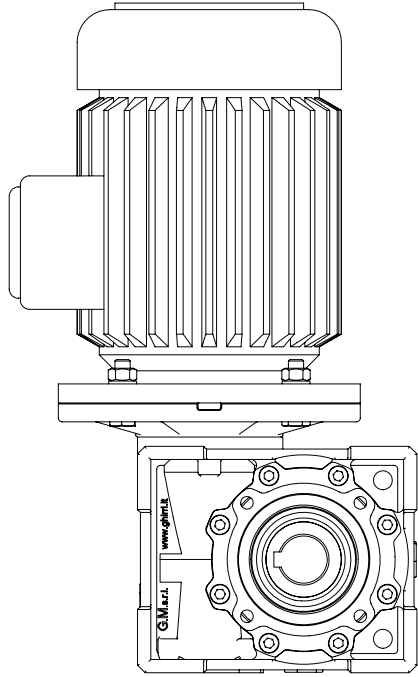

B 3

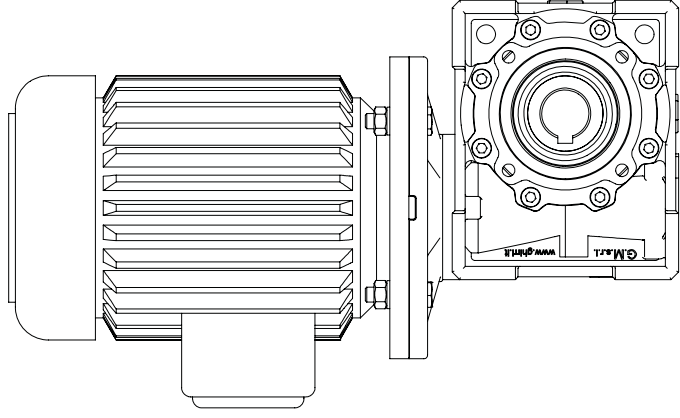

B 6

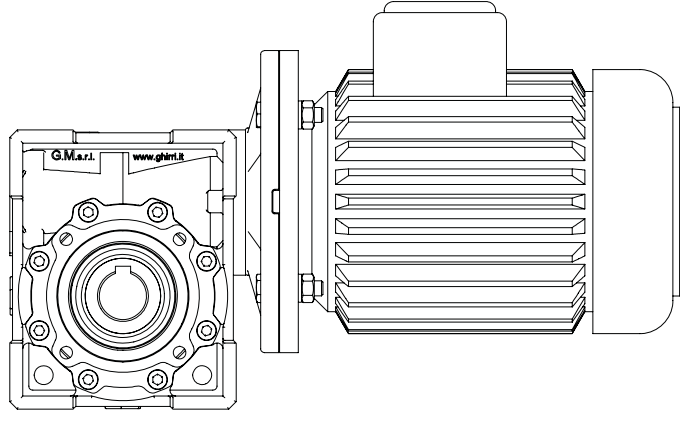

B 7

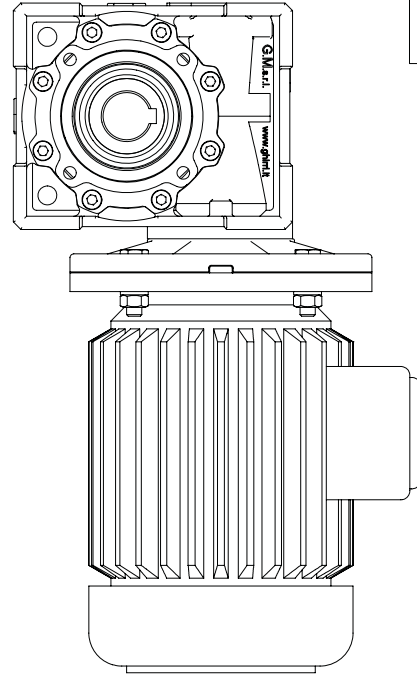

B 8

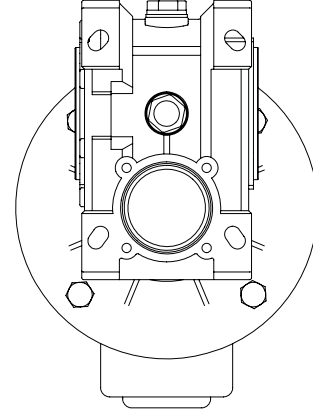

V 5

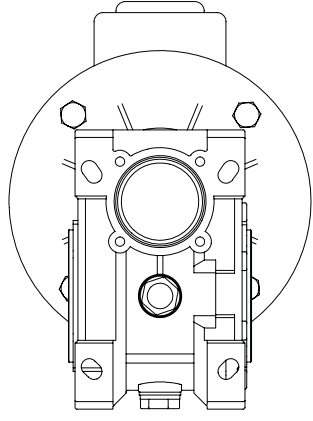

V 6



G.M. s.r.l.
Ghirri Motoriduttori

G.M. S.r.l. Ghirri Motoriduttori
Stabilimento e Uffici:
Via Prampolini, 6 - 41043 Formigine (MO), Italy
Tel. 059.55.82.10 - Fax 059.57.26.56
web-site: www.ghirri.it - e-mail: info@ghirri.it